



HDP-2

Hybrid-Dipole Surround Loudspeaker

OWNER'S MANUAL

Now Hear This
6400 Goodyear Road
Benicia, CA 94510
800-NHT-9993

Thank you for your purchase of the HDP-2 Hybrid Dipole Surround Loudspeaker. Please take a few minutes to read through this Owner's Manual prior to installing your new speakers. The information provided will help you to obtain maximum performance from your audio system. If you have questions or need assistance at any time during the installation or operation of your new speakers, please call your NHT dealer or our Toll Free Customer Hotline at:

1-800-NHT-9993

Please retain the HDP-2's packaging to protect the speakers in the event that you move or transport them.

HDP-2 Specifications

- **System Type:** 2-way acoustic suspension, hybrid dipole design
- **Driver Complement:** 6.5" long-throw woofer, (2) 1" fluid-cooled soft dome tweeters, (2) 4.5" long-throw woofers
- **Crossover:** 200 Hz, 12 db/octave, 2.8 KHz, 12 db/octave
- **Response:** 57Hz - 20KHz, +/- 3dB
- **Sensitivity:** 87db (2.83V at 1M)
- **Power Rating:** 10 W/ch minimum, 125 W/ch maximum
- **Impedance:** 6 ohms nominal, 3.2 ohms minimum
- **Inputs:** 1 pair of 5-way binding posts
- **Weight:** 18.5 lbs. each
- **Dimensions:** 9"H x 18"W x 7.5"D
- **Finish:** High gloss black or white laminate

Specifications are subject to change without notice, in accordance with our policy of continuously upgrading the performance of our products.

■ Design

NHT speakers are designed to deliver refined, musical sound from attractive and affordable packages. Our efforts are guided by the study of human hearing and are optimized for real-world use. Every NHT speaker undergoes rigorous testing and quality control at the factory to ensure you years of listening pleasure.

The HDP-2 is designed to provide diffuse, non-localizable sound radiation when used as rear (surround) speakers in a digital 5.1-channel home theater system. The HDP-2 was designed with a natural tonal balance that allows it to be used in conjunction with any of NHT's direct-radiating speakers. It is an ideal surround speaker in rooms where the listening position is close to the rear wall, as it projects an ambient soundfield around the listener when placed directly to the sides of the listening area.

The HDP-2 is a *hybrid dipole* design which employs a unique combination of dipolar upper-range drivers that radiate sound in two directions, paired with a monopole woofer that fires toward the wall for low frequency reinforcement.

■ Placement

Prior to installing the HDP-2's, spend some time considering placement options. For best results, mount the HDP-2's directly to the side of the seating position (Fig. 1). Place the speakers at a minimum height of six feet, to achieve optimal sound and to provide sufficient head clearance. Mount the HDP-2's at least a few inches from the ceiling. The HDP-2 is designed for indoor use only.

When the HDP-2's are mounted on the side walls, it is very important that you mount the "right" speaker on the right side of the room and the "left" speaker on the left side of the room. The "right" speaker has a small round sticker with the letter "R" on its back panel. This is because the forward-firing drivers on the "right" HDP-2 are in-phase with the front (main) speakers in the system, while its rear-firing drivers are wired out of phase and must face the rear of the room in order to avoid cancellation effects with the front speakers. Similarly, the "left" HDP-2 features forward-firing drivers that are in-phase with the front speakers, and rear-firing drivers wired out of phase.

Alternately, the HDP-2's may be mounted on the rear wall behind the seating position, if the room necessitates this configuration. Again, it is preferable to mount the speakers at a minimum height of six feet, and at least a few inches from the ceiling. ***When mounted on the rear wall, it is very important that you switch the speakers around, using the "right" HDP-2 on the left and the "left" HDP-2 on the right.*** This is done to ensure that the HDP-2's radiate sound toward center of the room (listening area) in phase with the front speakers. Do not simply reverse the polarity to the HDP-2's as an alternative to switching them around. Reversing the polarity would put the HDP-2's woofers out of phase with the front speakers, causing cancellation effects.

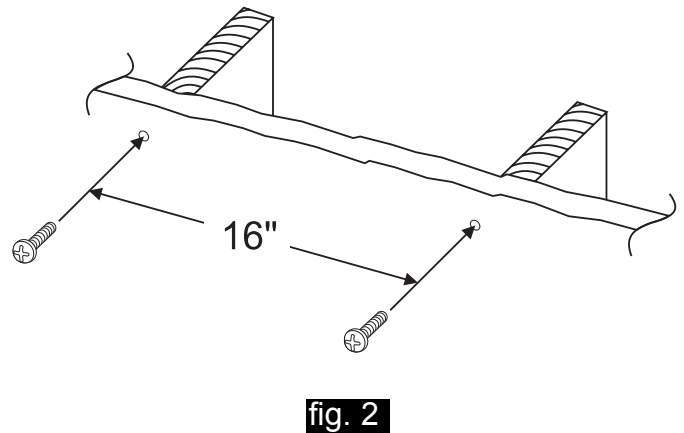
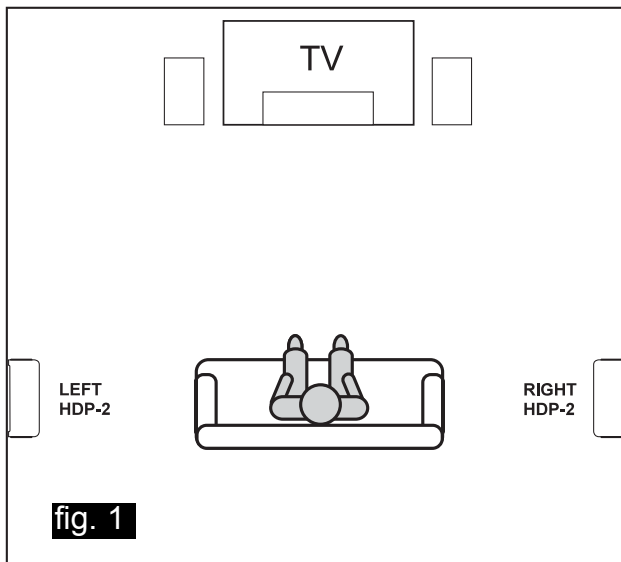

Experimentation is the key to finding the best arrangement in your listening environment. Be patient, have fun, and remember that small changes in speaker position can sometimes have a significant effect on the sound. In addition, room furnishings play an important role in absorbing and reflecting soundwaves. Midrange and high frequencies in particular will be absorbed by soft furnishings such as sofas, carpets and curtains. A large number of these soft furnishings will dull the sound, while a “live” room with few furnishings will brighten the sound. If you are willing to spend some time fine-tuning the performance of your system, you will enjoy the benefits for years to come.

■ Wall Mount Bracket

Parts List (per speaker):

- 2 screws (#10 x 2” pan head)
- 4 foam isolation pads
- 1 template (included with owner’s manual)

Tools you will need:

- power drill with 1/8-inch bit
- Philips screwdriver or power screwdriver
- studfinder
- level

Note: Whenever an object is affixed to a wall, you must take special care to mount it securely, to prevent it from falling and causing possible injury. THE HDP-2 MOUNTING BRACKET MUST BE ATTACHED TO STUDS, AS DRYWALL (SHEETROCK) ALONE CANNOT PROVIDE ADEQUATE SUPPORT. Make sure that the mounting bracket will not interfere with electrical wiring, plumbing, etc. IF YOU ARE UNSURE ABOUT THE INSTALLATION OF THIS MOUNTING BRACKET, CONSULT A PROFESSIONAL CONTRACTOR. Follow the mounting instructions carefully to ensure proper installation.

1. Begin by selecting the desired area on the wall where the HDP-2 will be mounted, preferably at a minimum height of 6 feet. Using a studfinder (or the old-fashioned “knocking” method), locate two adjacent studs, spaced 16 inches apart.
2. Using the supplied mounting template, mark the two screw locations, 16 inches apart and centered on the studs (Fig. 2). Use the level to ensure that the screw locations are lined up precisely.
3. Drill a 1/8-inch pilot hole into the wall for each screw. Be sure that the hole passes through the drywall and into the stud. If the hole does not reach a stud, re-position the screws and pilot holes until it does.
4. Insert one screw into each pilot hole. Screw all the way into the wall, until the screw head rests on the wall surface.
5. Loosen the screw 1 to 2 turns, so the bracket is able to slide down and the screw head will rest in the narrow section of the keyhole. The wall screws are now properly set.
6. Attach the four foam isolation pads to the back corners of the HDP-2 by peeling the backing paper and adhering them to the speaker surface (Fig. 3). These will prevent audible vibrations of the HDP-2 against the wall surface.
7. Attach speaker cable to the HDP-2. When possible in new construction applications, run the cable inside the wall and have it come out directly behind the location of the HDP-2. If this is not possible, simply run the cable along the wall behind the HDP-2. **The speaker cable must be a maximum of 1/4-inch thickness to fit between the wall and the HDP-2.**
8. Hold up the HDP-2 so that the top keyholes are aligned with the wall screws (Fig. 4). The other keyholes are not used for this product. Carefully place the brackets over the screws so that the screw heads slide into the round sections of the keyholes. Slowly move the HDP-2 downward until the bracket has locked over the screw. Ensure that both brackets are securely mounted to their screws.

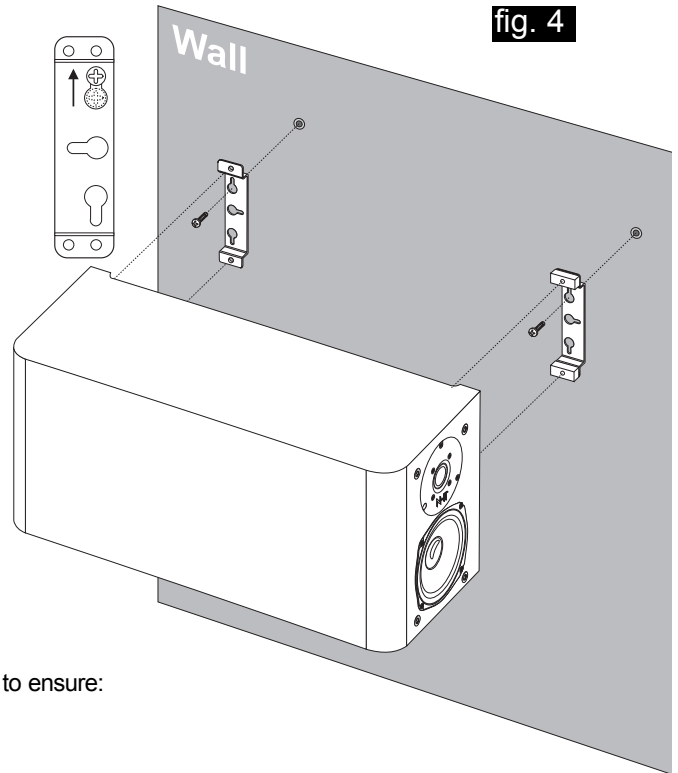
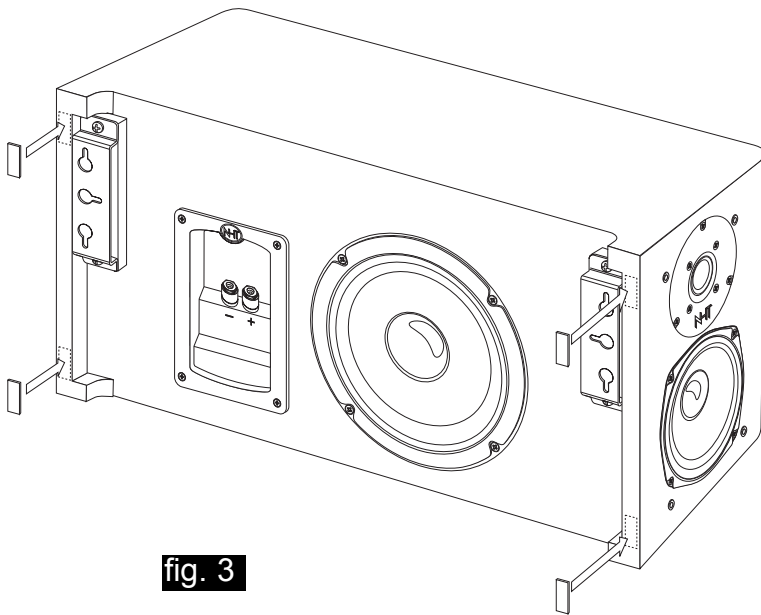

If you are unable to slide the HDP-2 brackets down onto the wall screws, check to ensure:

- Nothing is obstructing the speaker
- The brackets are mounted on the speaker facing opposite directions
- You are using the proper keyhole on both brackets
- The wall screws are exactly 16 inches apart, centered on the studs
- There is enough room between the screw head and the wall for the bracket to slide down.

■ Connections

Before connecting speakers to your system, it is very important that you turn off the power to your amplifier / receiver to avoid damage to the equipment.

The HDP-2 is compatible with virtually all quality amplifiers. Proper wiring of the speaker is essential to good sound. At a minimum, 16 AWG speaker cable is recommended for runs of 10 feet or less, with 14 AWG used for longer runs. For specialty cable considerations, consult your local authorized NHT retailer. For best results, use equal length runs of cable for all the speakers. Prepare your speaker cable by stripping 1/4" to 3/8" of insulation from the ends and twisting the exposed wire strands tightly. The five-way binding posts on the back of the speaker will accept raw wire, banana plugs, or spade plugs. Tighten the binding posts by hand, as pliers can strip or break them.

Be sure to wire all the speakers "in-phase." That is, the Positive (red) terminal on the amplifier output must be connected to the corresponding Positive (red) terminal on the speaker. Likewise with the Negative (black) terminals. All speaker cables have some sort of marking along one or both conductors to help you make the correct connections. Incorrect speaker phase is indicated by weak bass and the lack of a well-defined stereo image.

To minimize noise pickup, segregate cables by function. Do not run low level signal cables parallel to power cables, speaker cables, or digital cables. Also, do not run speaker cables or digital cables parallel to power cords or parallel to each other. If different types of cables are placed near each other at some place in your system, separate them by the maximum practical distance and cross them at right angles where they meet. Do not twist or tie AC power cords with speaker cables.

■ Operation

The HDP-2 was designed to handle a wide range of listening levels, but every speaker has limits. It is important to use common sense and listen for signs of possible distress from the speakers. Underpowered amplifiers are most often the cause of speaker damage. For example, a 60-watt amplifier runs out of power when called upon to produce more than 60 watts, and the resulting distortion can damage the speaker. If you tend to listen at high volumes, more powerful amplifiers are preferable because they are less likely to run out of power.

Noticeable distortion or harsh breakup is an indication that either your amplifier or your speakers are running beyond their capacity, and the volume should be decreased. If you can feel any heat emanating from the woofer or tweeter, reduce the level immediately. Speaker damage most often occurs from sustained high volume levels, not from transient sounds or brief musical peaks. Excessive boosting of bass, treble or equalizer controls can worsen the problem, and is not recommended.

■ Maintenance

Your speakers require minimal maintenance under normal use. The cabinet may be cleaned using a damp cloth or a mild, non-abrasive glass cleaner. To clean the grille, first remove it from the speaker, then brush lightly with a soft brush or use a vacuum on its lowest setting. Do not expose the speaker to direct sunlight, high temperatures, or moisture. Do not attempt to clean the actual drivers.

Limited Warranty

Valid Only in the U.S.A.

Warranty Period

For the period of 5 years for parts and 5 years for labor from date of original purchase (the warranty period) from an authorized NHT dealer, Now Hear This (NHT) warrants that if our product fails to function properly under normal use due to a manufacturing defect when installed and operated according to the owner's manual instructions enclosed with the unit, it will be repaired or replaced with a unit of comparable value at the option of NHT without charge to you for parts or actual repair work. Parts supplied under this warranty may be new or rebuilt at the option of NHT.

What's Not Covered

This warranty does not cover any product which is used in any trade or business, or in an industrial or commercial application.

This warranty does not cover the cabinet or any appearance item, or any damage caused to the product resulting from: alterations, modifications not authorized in writing by NHT, accident, misuse or abuse, damage due to lightning or power surges, or being subjected to power in excess of the speaker's published power rating.

This warranty does not cover the cost of parts which would otherwise be provided without charge under this warranty, obtained from any source other than an authorized NHT service location. This warranty does not cover defects or damage caused by the use of unauthorized parts or labor or from improper maintenance.

Altered, defaced or removed serial numbers void this warranty.

Your Rights

The liability of NHT will be limited to the purchase price of the product, and NHT will not be liable for incidental or consequential damages. NHT limits its obligations under any implied warranties under state laws to a period not exceeding the warranty period. Some states do not allow limitations on how long an implied warranty lasts, and some states do not allow the exclusion or limitation of incidental or consequential damages. The above limitations or exclusions may not apply to you. This warranty gives you specific legal rights, and you may have other rights which vary from state to state.

To Obtain Service

NHT has appointed a number of authorized service companies throughout the USA should your product ever require service. To receive warranty service, you will need to present your sales receipt showing place and date of original owner's transaction.

To find the name and address of the nearest authorized NHT service location, call or write:
Customer Service Department, Now Hear This, 6400 Goodyear Road, Benicia, CA 94510.
1-800-NHT-9993.

Please do not return product to this address. It is not a service location.

Keep this warranty with your sales receipt. Record date and place of purchase for future reference.